

Romilda

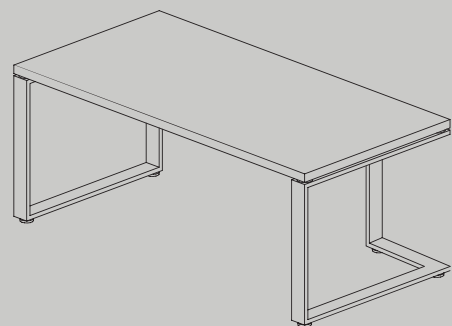

direzionali | executive | mobilier de direction | ejecutivos

auraa
design

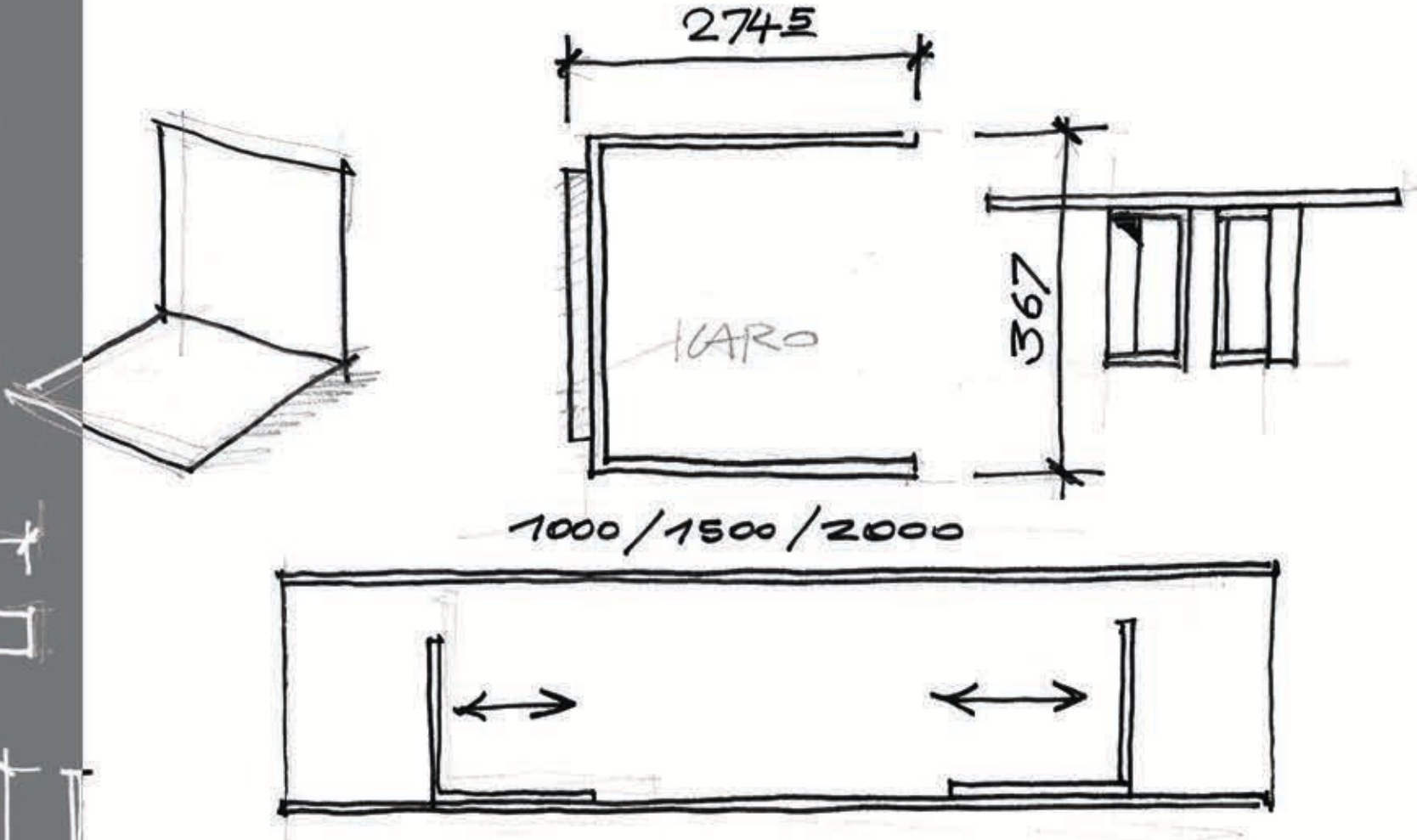
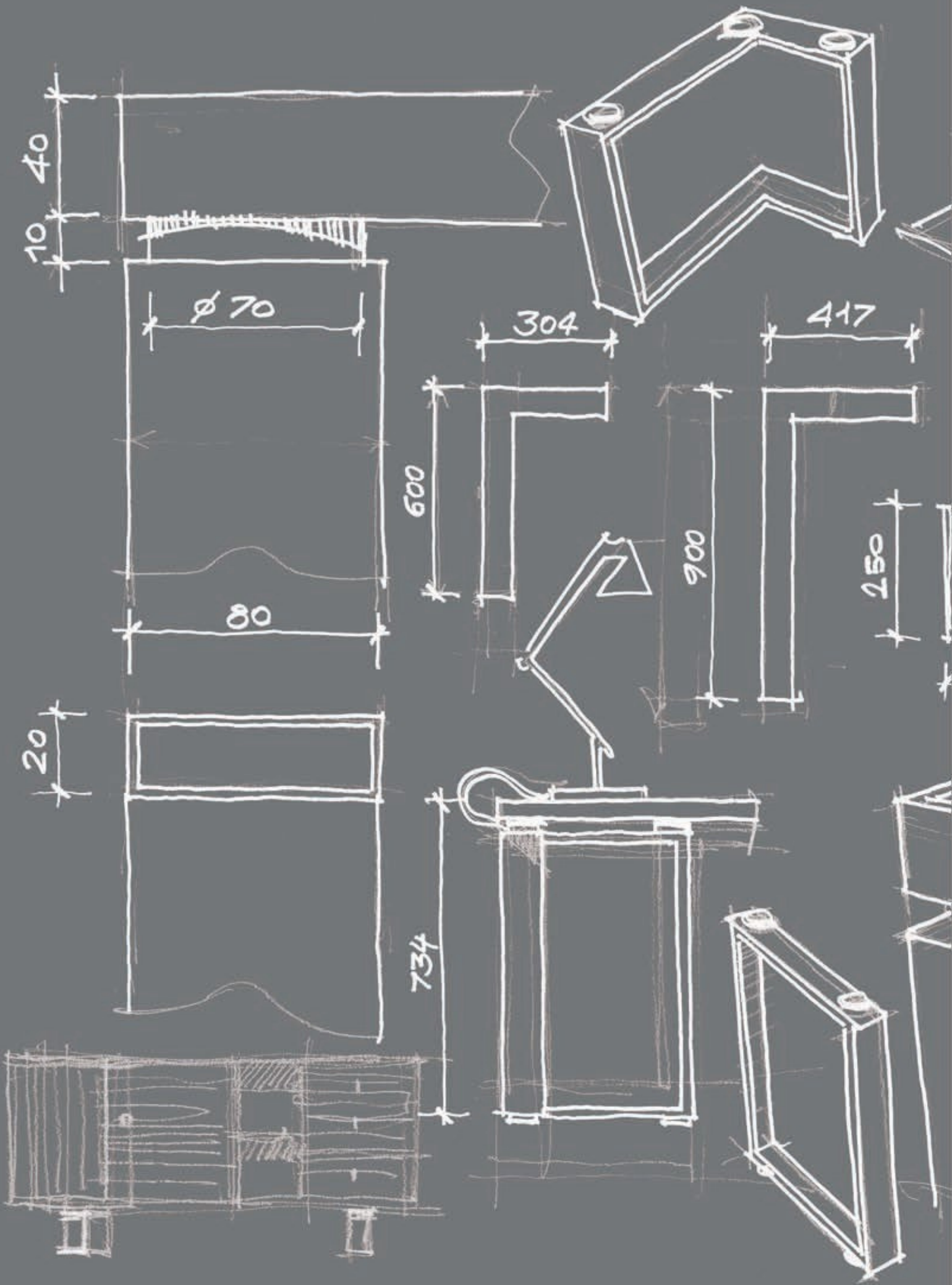

Nuovi componenti e finiture: Romilda rinnova la sua immagine e moltiplica le proprie soluzioni di arredo. Il design si mantiene lineare e contemporaneo, con i piani lavoro ortogonali abbinati alla gamba strutturale ad anello o a quella 'irregolare', ma sono state aggiunte nuove opzioni estetiche (come la cornice 'brill' anche per i piani lignei) e strutturali (il contenitore laterale che funge da supporto al piano lavoro).

A new look and more design solutions for Romilda. The design is still contemporary, with work surfaces perpendicular to both the supporting ring leg and "L-shape". New styles & structural options have been added such as the "brill" (polished aluminum) frame for wood tops and a side cabinet supporting the desk surface.

Nouveaux composants et finitions: Romilda renouvelle son image et multiplie les solutions d'aménagement. Le design reste lineaire et contemporain, avec des plateaux orthogonaux en harmonie avec le piétement structurel en anneau ou à celui "irregulier". De nouvelles options esthétiques (comme le cadre "brill" disponible également pour les plateaux en bois et structurels (le caisson lateral qui devient support du plateau))

Nuevos componentes y acabados: Romilda renova su imagen y multiplica sus soluciones de decoración. El diseño sigue siendo contemporáneo y estilizado, con las superficies de trabajo ortogonales que se combinan a la pata estructural en anillo o a la "irregular". Se han añadido nuevas opciones estéticas (como el marco "brill" también para los sobes en melamina y madera) y estructurales (el contenedor lateral que funciona como soporte al sobre de trabajo)

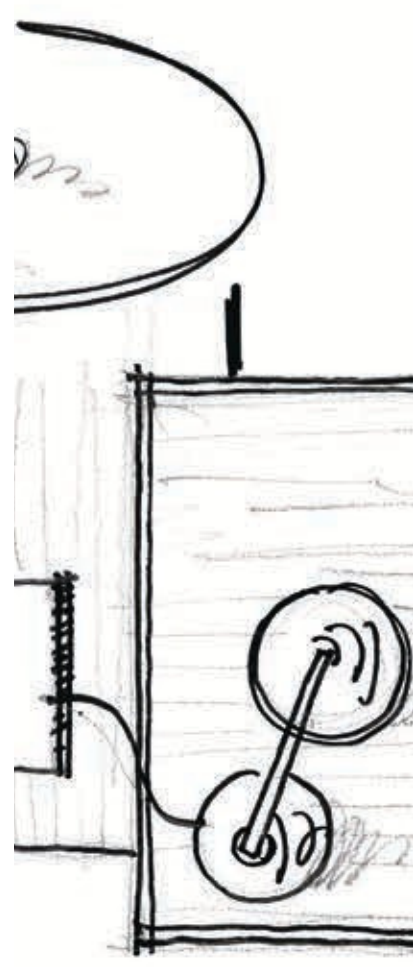



MATÉRIEL & DESIGN



MATERIA & DESIGN



RAW MATERIAL & DESIGN



2



MATÉRIEL & DESIGN

3

Il cuoio è il materiale più prestigioso per il tavolo direzionale. Romilda lo propone sui piani lavoro in vari colori con cuciture tinta Grigio Perla, incorniciato da un perimetro in finitura brillantata che enfatizza l'unicità del rivestimento e i dettagli materici.

Leather is the most prestigious finish on an executive table. A variety of leather colours are offered in this series always with Pearl Grey color stitching. Each side of the table top is finished with a polished aluminum edge so that the beauty and quality of the leather are highlighted.

Le cuir est le matériel le plus prestigieux pour la table de direction. Romilda le propose sur les plateaux en différents coloris avec des surpiqûres en Gris Perle, avec un encadrement brillant qui souligne les détails des matériaux et des revêtements.

El cuero es el material más prestigioso de la mesa ejecutiva. Romilda propone sobres de trabajo en una variedad de colores con costuras acabado en Gris Perla, enmarcado por un perímetro en acabado brillante que acentúa la singularidad del revestimiento.



Cuoio - Leather - Cuir - Cuero

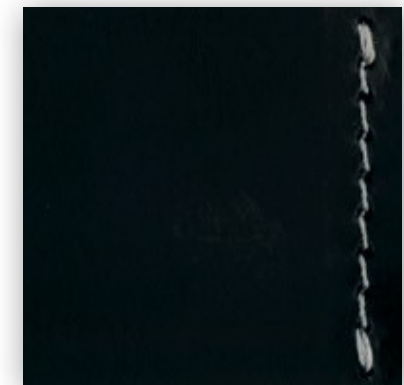
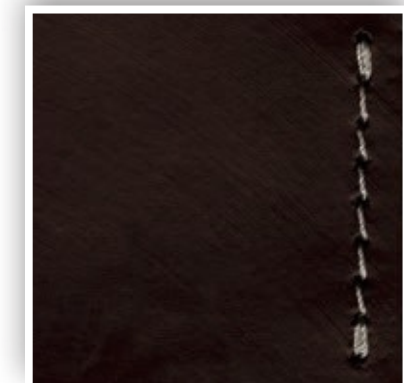
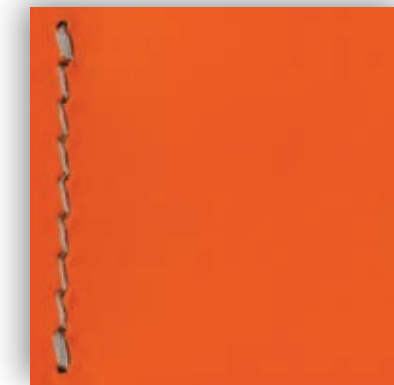

I piani lignei (sia in essenza che in melaminico) presentano una doppia soluzione per il bordo. Lo si può avere sia abbinato alla finitura del piano che realizzato con cornice brillantata. L'abbinamento cromo/legno conferisce un'immagine più tecnica alla scrivania.

The wood tops, both veneer & melamine, come with 2 edge options. It can either match the top or have a polished aluminum finish. The latter provides a more technical look to the desk overall.

Les plateaux (en bois et en mélamine) présentent une double solution pour le chant. Il peut être soit de la même couleur du plateau soit avec encadrement brillant. L'association chrome/bois donne un aspect plus technique au bureau.

Los sobres en madera y melamina presentan una doble solución para el canto. El canto se puede realizar en el mismo acabado que el sobre de mesa o con marco brillante. La combinación de cromo / madera da una imagen más técnica de la mesa.



Legno - Wood - Bois - Madera



Sono numerose le opzioni possibili per i piani in melaminico: dalle finiture legno, ai colori neutri nella esclusiva finitura 'millerighe', alle tinte unite chiare o scure. Le combinazioni realizzabili abbinando struttura metallica e piani sono molte e rendono Romilda un prodotto molto versatile e facilmente adattabile ai diversi ambienti di lavoro.

There are many options for melamine tops: from wood finishes to neutral colors in the exclusive "ribbed" finish, to solid bright or dark colors. With multiple pairing options between the metal structure and the worksurfaces, Romilda becomes an easy fit for a wide range of working environments.

De nombreuses options sont possibles pour les plateaux en mélaminé: finitions bois, coloris neutres, finition "millerighe", teintes unies claires ou foncées. Les combinaisons possibles avec la structure en métal et les plateaux sont multiples et font Romilda un produit très flexible et adaptable aux différents aménagements des espaces de travail.

Hay muchas opciones para los sobres en melamina: de los acabados de madera, a los colores neutros en el exclusivo acabado «mil rayas», a los colores lisos brillantes o oscuros. Las diferentes combinaciones mediante la combinación de la estructura metálica y los sobres diferentes acabados en sobres de mesa son muchas y hacen Romilda muy versátil y fácilmente adaptable a diferentes ambientes de trabajo.



Melaminico - Melamine - Mélaminé - Melamina



Romilda si arricchisce di una nuova opzione: il piano lavoro in gres porcellanato con telaio perimetrale in alluminio spazzolato. Il piano in gres e' disponibile in quattro finiture di tendenza: corten, basalto, calacatta, pulpis, e rappresenta un'originale alternativa ai materiali tradizionali.

Romilda has been enhanced with a new option: the work tops with porcelain tiles and perimeter frame in brushed aluminum. The porcelain features contemporary finishes: corten, basalt, calacatta and pulpis, and represents a genuine alternative to traditional materials.

Romilda se dote d'une nouvelle option: Un plan de travail en "grès porcelaine" entouré d'une cadre en aluminium brossé. Le plan de grès est disponible en quatre finitions tendances: Corten, Basalte, Calacatta et Pulpis. Ce qui représentent de belles alternatives aux matériaux traditionnels.

Romilda se ha mejorado con una nueva opción: las cubiertas de trabajo con azulejos de porcelana y marco perimetral en aluminio cepillado. La porcelana presenta acabados de moda: corten, basalto, marmol tipo calacatta y piedra pulpis y representa una auténtica alternativa a los materiales tradicionales.



**Gres porcellanato - Porcelain tiles - Grès porcelaine
Azulejos de porcelana**

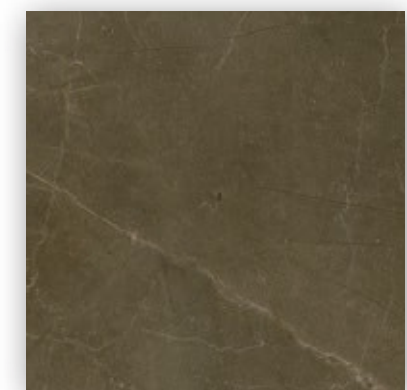

Agli appassionati del vetro, Romilda propone piani extra-light retrolaccati in vari colori e incorniciati da una perimetria in alluminio con finitura brillantata. L'immagine che ne deriva è quella di un ambiente molto tecnico, contemporaneo ed elegante.

For the glass lovers, Romilda offers extra-light, back painted glass tops available in many colors with a polished aluminum frame. The final result is a sophisticated and contemporary office solution.

Pour les amateurs de verre, Romilda propose des plateaux extra-light lacqués dans plusieurs finitions avec un contour en aluminium finition brillant conférant à l'espace une image technique, élégant et contemporain.

Para los apasionados del cristal, Romilda ofrece sobres extra claros en varios colores y enmarcados por un marco de aluminio con acabado brillante. La imagen que surge es la de un ambiente muy técnico, contemporáneo y elegante.



Vetro - Glass - Verre - Cristal

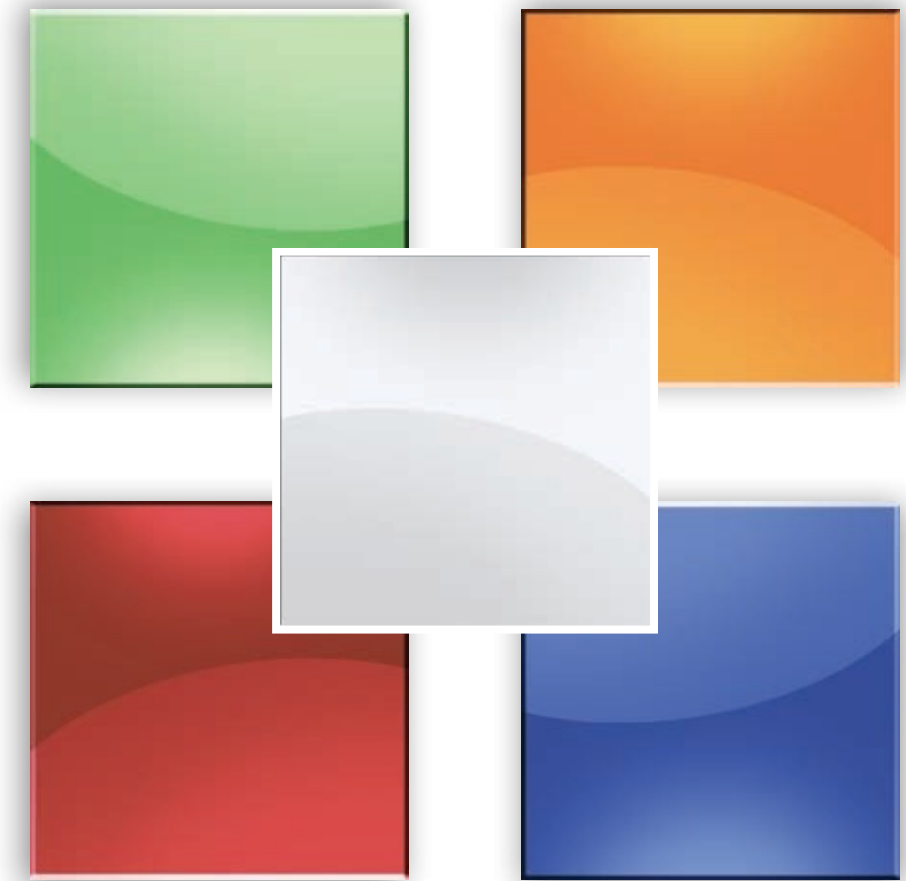



Romilda comes with a wide choice of finishes in melamine. A storage system with open bookcases or hinged doors and mobile service units are available as well.

Romilda offre une large gamme de choix entre les finitions en mélaminé. Viennent compléter les bibliothèques modulables, ouvertes ou avec portes battantes, et meubles sur roulettes.

Romilda ofrece una amplia gama de opciones entre acabados en melamina. Para completar el mobiliario hay estanterías modulares, abiertas o con puertas batientes, y muebles auxiliares con ruedas.

Romilda offre una ampia possibilità di scelta tra le finiture in essenza di legno e quelle in melaminico. A completare l'arredo concorrono librerie modulari, a giorno o con ante battente e mobili di servizio su ruote.

Romilda



Romilda



Romilda

The back painted glass tops framed in polished aluminum are available in many colors and they are a perfect match for bookcases and cabinets in a melamine solid color. Romilda legs have always two versions, 'L' or ring-shape.

Le plateau en verre lacqué, avec chant en finition brillant, est disponible dans plusieurs coloris et ABBINARE aux bibliothèques et caissons en mélamine uni. Le piètement Romilda est toujours disponible en version à anneau linéaire ou moulure.

El sobre en cristal retrolacado, enmarcado por el perfil en acabado brillante, está disponible en varios colores y se combina con estanterías y cajoneras en melamina. La pata de Romilda está siempre disponible en dos versiones, o en forma de anillo o en forma de L.



Il piano in vetro retrolacato, incorniciato dal profilo in finitura brillantata, è disponibile in vari colori e si abbina a librerie e cassetiere in melaminico tinta unita. La gamba di Romilda è sempre disponibile nella doppia versione ad anello lineare o sagomato.

Romilda



Romilda 1



Romilda 1

Romilda 2





Romilda 3





Romilda 3

A flip top is available for meeting tables and comes with a receiving trough for horizontal cable management. A plastic vertebra is provided for the vertical wiring management.

Sur les tables de réunion il est possible d'intégrer des top-access avec corbeille pour le câblage. Les passages de câbles verticaux se font avec des vertèbres en plastique.

En las mesas de reuniones es posible colocar "top-access", equipados de bandeja para los cables. La canalización vertical, se realiza mediante vértebras en material plástico.



Nei tavoli riunione è possibile inserire top-access a doppio verso di apertura, dotati di vasca di appoggio per il cablaggio. La canalizzazione verticale viene affidata a vertebre in materiale plastico.

Romilda 6



La libreria Archimede è definita da una struttura con disegno ad L, confermando la geometria distintiva della collezione. Viene proposta nella variante con 5 ripiani oppure ripiani e vano TV.

The Archimede bookcase is defined by an L-shaped structure, confirming the distinctive geometry of the collection. It is available in the variant with 5 shelves or shelves and TV compartment.

La bibliothèque Archimede est définie par une structure en forme de L, confirmant la géométrie distinctive de la collection. Elle est disponible dans la variante avec 5 étagères ou étagères et compartiment TV.

La librería Archimede se define por una estructura en forma de L, que confirma la geometría distintiva de la colección. Está disponible en la variante con 5 estantes o estantes y compartimento para TV.



Piani | Desk tops | Plateaux | Sobres
Spessore 4 cm | 4 cm (1 5/8") thick | 4 cm d'épaisseur | 4 cm de espesor

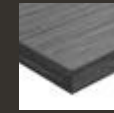

Senza profilo - legno/melaminico
 Without profile - wood veneer/Italian melamine
 Sans profil - bois/mélaminé
 Sin perfil - madera/melaminico

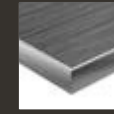

Con profilo - legno/melaminico/cuoio/vetro/gres
 With profile - wood veneer/Italian melamine/leather/glass/porcelain tiles
 Avec profil - bois/mélaminé/cuir/verre/gres cérame
 Con perfil - madera/melaminico/cuero/vidrio/gres porcelánico

Gambe | Legs | Pieds | Patas
Sezione 8x2 cm | Section 8x2 cm (3 1/8"x3/4") thick | Section 8x2 cm | Sección 8x2 cm

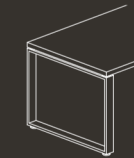

Gamba ad anello
 Ring leg
 Pied en anneau
 Pata en anillo

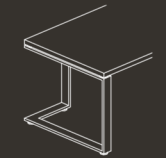

gamba a L
 L leg
 pied en L
 pata en L



Gamba a T
 T leg
 Pied en T
 Pata en T

Scrivanie | Desks | Bureaux | Mesas

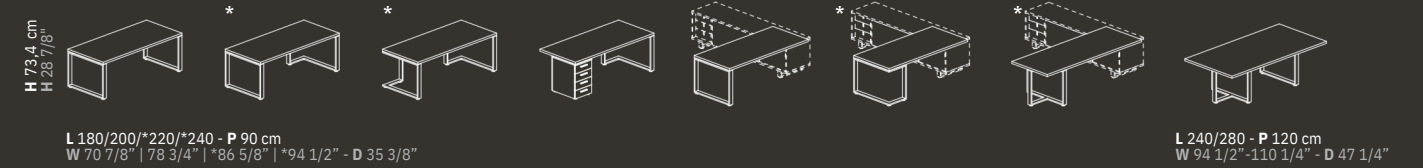

Dattilo | Returns | Retours | Alas

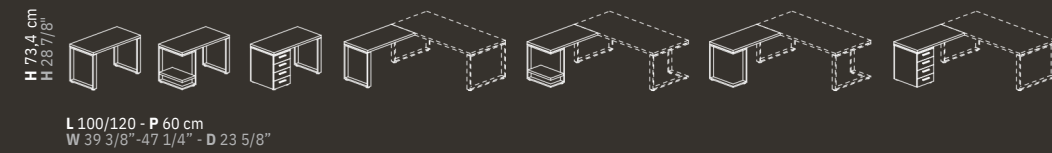

Tavoli riunione | Meeting tables | Tables de réunion | Mesas de juntas

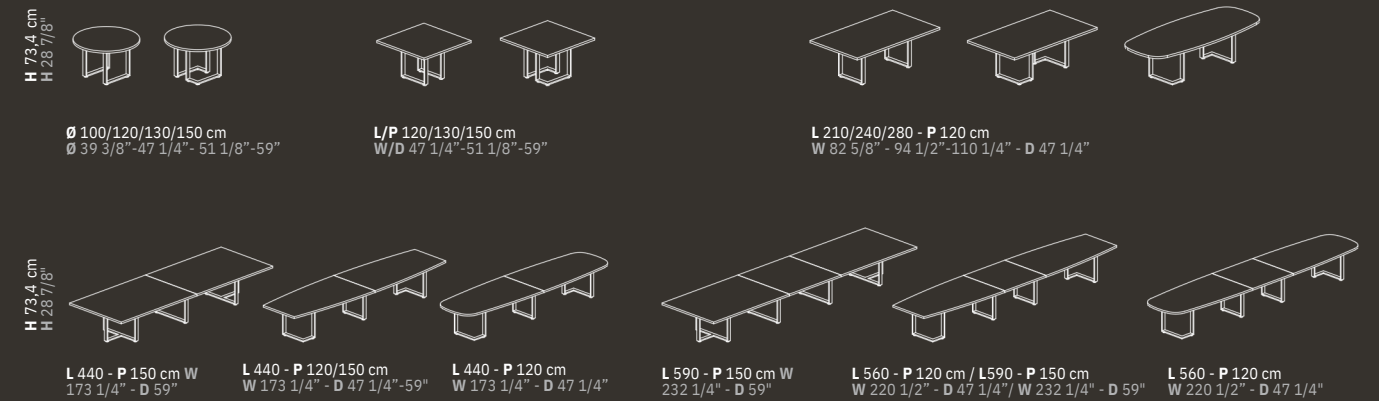

Mobili di servizio | Service units | Meuble retour | Muebles de servicio

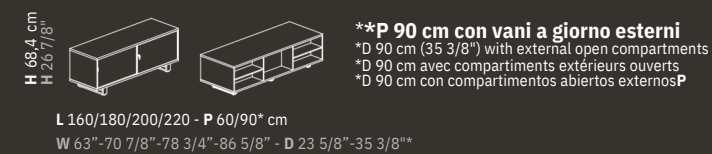

Tavolini da caffè | Coffee tables | Tables basses | Mesitas



Librerie | Bookshelves | Bibliothèque | Libreros

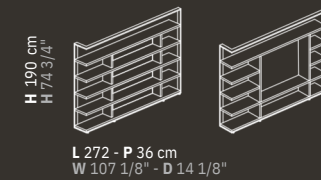









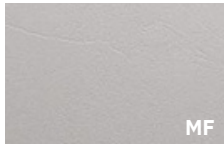

Finiture | Finishes | Finitions | Acabados

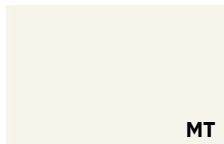
MEL

Melaminico

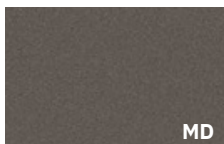
Melamine | Mélaminé | Melaminico

TOP MOB MOD



 MB	 MG	 MF	 MZ	 MN
Bianco rigato Rippled effect white Blanc avec rayures en sérigraphie Blanco rayado	Grigio rigato Rippled effect grey Gris avec rayures en sérigraphie Gris rayado	Nichel Nickel Nickel Niquel	Cacao Cocoa Cacao Cacao	Bianco White Blanc Blanco
 MT	 MJ	 MK	 MI	 MV
Talco Talco Talco Talco	Ocra Ochre Ocre Ocre	Safari Safari Safari Safari	Noisette Noisette Noisette Noisette	Verde Green Vert Verde
 ML	 MQ	 MD	 MC	 MY
Nero Black Noir Negro	Blu notte Night blue Bleu nuit Azul noche	Ardesia Ardesia Ardesia Pizarra	Rovere chiaro Light oak Chêne clair Roble claro	Rovere americano American oak Chêne américain Roble americano
 ME	 MM	 MO	 MW	
Rovere grigio Grey oak Chêne gris Roble gris	Rovere moro Dark oak Chêne foncé Roble oscuro	Noce Canaletto Canaletto Walnut Noyer Canaletto Nogal Canaletto	Noce scuro Dark walnut Noyer foncé Nogal oscuro	

LGN

Legno

Wood | Bois | Madera

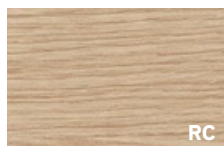
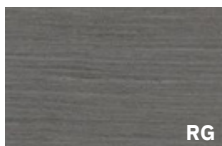
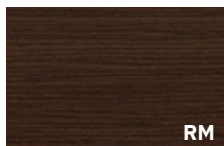
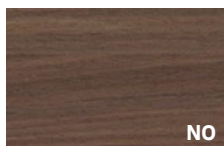
TOP MOB MOD

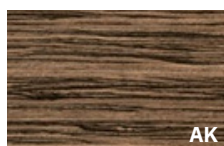
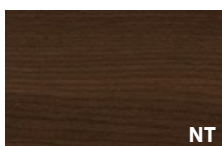







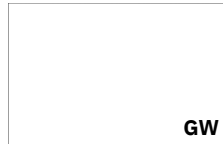
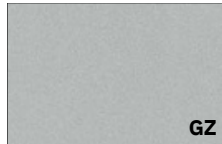

 RC	 RG	 RM	 NO	 SL
Rovere chiaro Light oak Chêne clair Roble claro	Rovere grigio fumo Smoke grey oak Chêne gris de fumée Roble gris humo	Rovere moro Dark oak Chêne foncé Roble oscuro	Noce Canaletto Canaletto walnut Noyer Canaletto Nogal Canaletto	Ebano silver Silver ebony Ebony silver Ebano plata
 AK	 NT			
Ebano Makassar Makassar ebony Ebony Makassar Ebano Makassar	Noce termocotto Heat-treated walnut Noyer thermo traité Nogal termotratado			

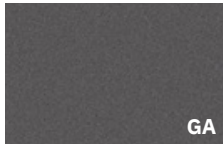
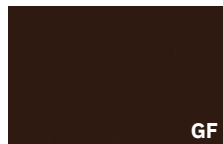
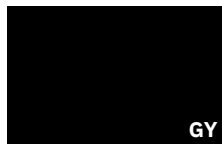
VTR

Vetro (anche antimpronta NFG)

Glass (also antifinger NFG) | Verre (également antitaches) | Vidrio (también anti-huella)

TOP



 GW	 GZ	 GK	 GN	 GA
Bianco White Blanc Blanco	Argento Silver Argent Plata	Grigio scuro Dark grey Gris foncé Gris oscuro	Noisette Noisette Noisette Noisette	Ardesia Ardesia Ardesia Pizarra
 GF	 GY	 GX	 GQ	 GO
Moka Mocha Moka Cafe	Nero Black Noir Negro	Arancione Orange Orange Naranja	Rosso "F" Red "F" Rouge "F" Rojo "F"	Rubino Ruby Rubis Rubi
 GD	 GT	 GU	 GR	
Indaco Indigo Indigo Azul Indigo	Azzurro Blue Bleu Azul	Verde Green Vert Verde	Cedro Lime green Vert Cédrat Verde Cedro	

GRES

Gres porcellanato

Porcelain tiles | Grès cérame | Gres porcelánico

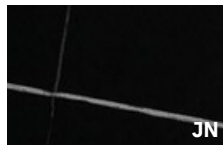
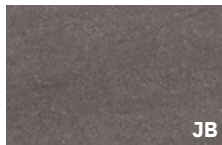
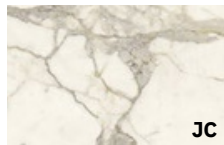
TOP

 JN	 JB	 JC	 JP	 JR
Nero Black Noir Negro	Basalt Basalt Basalt Basalt	Calacatta Calacatta Calacatta Calacatta	Pulpis Pulpis Pulpis Pulpis	Corten Corten Corten Corten

CUO

Cuoio

Leather | Cuir | Cuero



Bianco
White
Blanc
Blanco



Alluminio
Aluminium
Aluminium
Aluminio



Nero
Black
Noir
Negro



Testa di moro
Brown
Tete de maure
Marron oscuro



Caramello
Caramel
Caramel
Caramelo

TOP



Arancione
Orange
Orange
Naranja

MTC

Metacrilato

Acrylic | Méthacrylate | Metacrilato

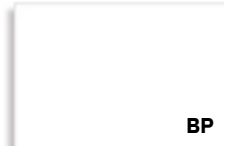

Bianco opalino
Opaline white
Blanc opalin
Blanco opaco

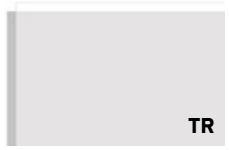

Trasparente
Transparent
Transparent
Transparente



Rosso trasparente
Red transparent
Rouge transparent
Rojo transparente



Blu trasparente
Blue transparent
Bleu transparent
Azul transparente



Bianco satinato
Satin-finish white
Blanc satiné
Blanco satinado

MOB



Grigio fumè satinato
Satin-finish smoky grey
Gris satiné
Gris satinado



Arancione satinato
Satin-finish orange
Orange satiné
Naranja satinado



Blu satinato
Satin-finish blue
Bleu satiné
Azul satinado



Verde satinato
Satin-finish green
Vert satiné
Verde satinado

GOF

Metacrilato retrolaccato

Backpainted acrylic | Méthacrylate rétro-laqué | Metacrilato retrolacado



Bianco
White
Blanc
Blanco



Argento
Silver
Argent
Plata



Grigio scuro
Dark grey
Gris foncé
Gris oscuro



Noisette
Noisette
Noisette
Noisette



Ardesia
Ardesia
Ardesia
Pizarra

MOB



Moka
Mocha
Moka
Cafe



Nero
Black
Noir
Negro



Arancione
Orange
Orange
Naranja



Rosso "F"
Red "F"
Rouge "F"
Rojo "F"



Rubino
Ruby
Rubis
Rubi



Indaco
Indigo
Indigo
Azul Indigo



Azzurro
Blue
Bleu
Azul



Verde
Green
Vert
Verde



Cedro
Lime green
Vert Cédrat
Verde Cedro

CRM

Acciaio inox

Stainless steel | Acier inoxydable | Acero inoxidable



Lucido
Polished
Poli
Pulido

STRU



Brill
Brill
Brill
Brill

PR

AL

Alluminio

Aluminium | Aluminium | Aluminio



Alluminio
Aluminium
Aluminium
Aluminio

PR

EPX

Epossidico

Epoxy | Époxy | Epoxi

PR

STRU

EB	ET	EG	YD	EO
Bianco White Blanc Blanco	Talco Talco Talco Talco	Grigio Grey Gris Gris	Beige Arizona Arizona beige Beige Arizona Beige Arizona	Noisette Noisette Noisette Noisette
EK	EE	YB	EZ	YQ
Safari Safari Safari Safari	Rame Copper Cuivre Cobre	Rosso Jaipur Jaipur red Rouge Jaipur Rojo Jaipur	Bronzo Bronze Bronze Bronce	Blu notte Night blue Bleu nuit Azul noche
YC	EI	YV	EN	
Grigio Bromo Bromo grey Gris Bromo Gris Bromo	Ardesia Ardesia Ardesia Pizarra	Verde Comodoro Comodoro green Vert Comodoro Verde Comodoro	Nero Black Noir Negro	

Applicazioni finiture

Finish application | Application finitions | Aplicacion acabados

TOP

Piano
Top
Plateau
Sobre

MOD

Modesty panel
Modesty panel
Voile de fond
Faldón

MOB

Mobile di servizio
Service unit
Meuble de service
Mueble de servicio

STRU

Struttura
Structure
Structure
Structura

PR

Profilo scrivania
Top edge
Chant plateau
Perfil sobre de mesa

ecologia

I prodotti utilizza per i suoi prodotti e i suoi imballi materiali facilmente separabili e riciclabili.

attestazione di prodotto

I prodotti sono stati sottoposti a prove prestazionali presso laboratori di prova accreditati. Copia dei rapporti di prova o delle attestazioni di conformità sono disponibili su richiesta. I prodotti soddisfano i requisiti LEED per il credito IEQ4.5 per i materiali a bassa emissione ed i requisiti ANSI/BIFMA X7.1-2011. Il produttore dichiara di utilizzare pannelli a base di legno aventi un rilascio di formaldeide conforme alla classe E1 secondo il DM 10/10/2008. Il produttore si impegna inoltre ad utilizzare materiali legnosi FSC e pannelli a base di legno con certificazione CARB2.

environnement

The products and packaging are made of recyclable materials.

product certification

The products have been subjected to performance tests at accredited testing laboratories. Copies of test reports or certificates of conformity are available on request. The products meet the LEED requirements for IEQ4.5 credit for low emission materials and the ANSI/BIFMA X7.1-2011 requirements. The manufacturer declares to use wood-based panels with a formaldehyde release according to class E1 according to DM 10/10/2008. The manufacturer also undertakes to use FSC wood-based materials and CARB2-certified wood-based panels.

environnement

Les produits utilise des matériaux facilement séparables et recyclables pour ses produits et ses emballages.

certification de produits

Les produits ont été soumis à des tests de performance dans des laboratoires accrédités. Des copies des rapports d'essais ou des certificats de conformité sont disponibles sur demande. Les produits répondent aux exigences LEED pour le crédit IEQ4.5 pour les matériaux à faibles émissions et aux exigences ANSI/BIFMA X7.1-2011. Le fabricant déclare utiliser des panneaux à base de bois avec un dégagement de formaldéhyde selon la classe E1 selon DM 10/10/2008. Le fabricant engage également à utiliser des matériaux à base de bois FSC et des panneaux à base de bois certifiés CARB2.

ecología

Los productos utiliza productos y embalajes en materiales fácilmente separables y reciclables.

certificación de producto

Los productos han sido sometidos a pruebas de rendimiento en laboratorios de pruebas acreditados. Copias de los informes de las pruebas o certificados de conformidad están disponibles bajo petición. Los productos cumplen con los requisitos LEED para el crédito IEQ4.5 para materiales de baja emisión y los requisitos ANSI/BIFMA X7.1-2011. El fabricante declara utilizar paneles de madera con una emisión de formaldehído según la clase E1 según DM 10/10/2008. El fabricante también se compromete a utilizar materiales a base de madera FSC y paneles a base de madera certificados por CARB2.

aura design



Hub Spaces, 582 Honeypot Lane, Stanmore, HA7 1JS, UK
www.auraadesign.co.uk
020 3915 8008
info@auraadesign.co.uk

