

aura
design

www.auraadesign.co.uk

GIADA

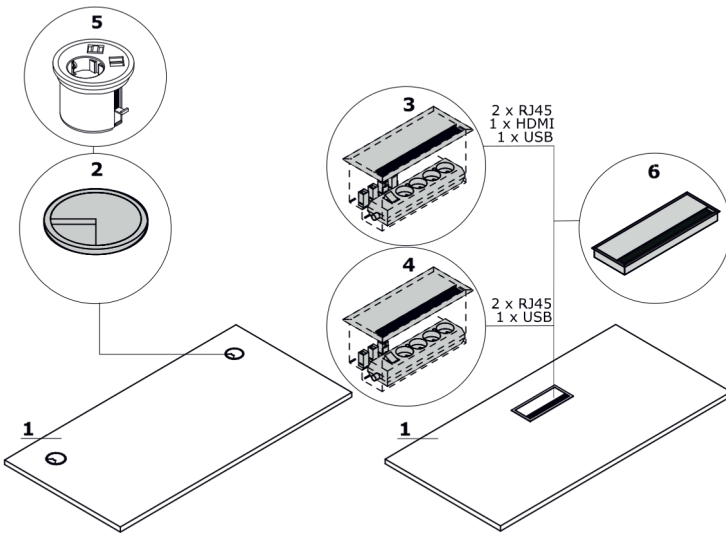



1. Worktop - MFC 28 mm, ABS edge

OPTIONS WITH EXTRA CHARGE:

2. Grommet - 2 pcs, Ø 80 mm

3. Mediabox - 2 x RJ45 (class E, cat. 6); + 1 x USB + 1 x HDMI + 4 x 230V

4. Mediabox - 2 x RJ45 (class E, cat. 6); + 1 x USB + 4 x 230V

5. Mediabox - 1 x 230V + 1 x USB charger + 1 x RJ45, colour: black, white, mounted instead of the existing grommet Ø80 mm

6. Top access

7. Cable way - the width of the opening is proportional to the width of the worktop

8. Mediabox + cable grommets

9. Cable way + cable grommets - desks, bench desks

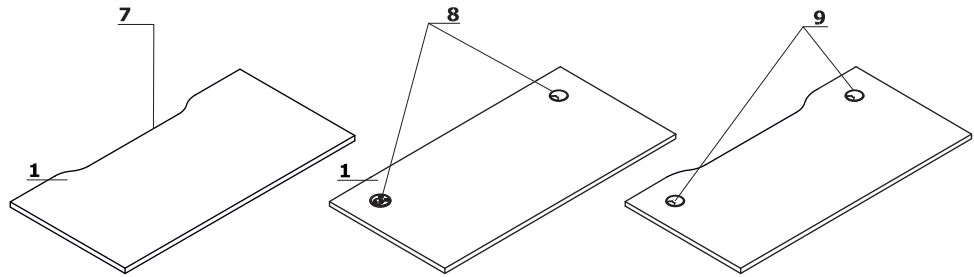

Frame

1. Giada with electric height adjustment - in the range of 650–1300 mm, metal, powder coated, 3 profiles 50 × 50 mm, 55 × 55 mm and 60 × 60 mm

2. Giada with electric height adjustment - in the range of 700–1200 mm, metal, powder coated, 2 profiles 55 × 55 mm and 60 × 60 mm

3. OPTION WITH EXTRA CHARGE - Pro foot: aluminium powder coated polished aluminium

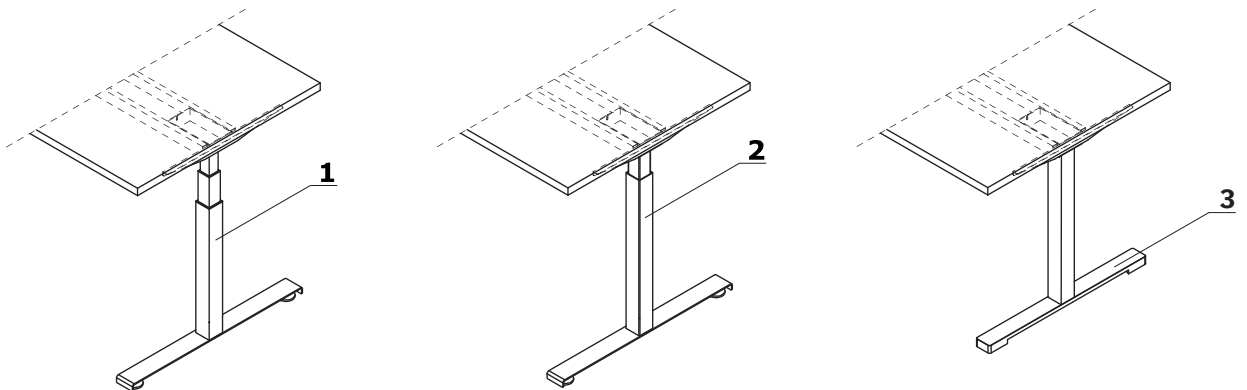

Electric height adjustable frame - Giada

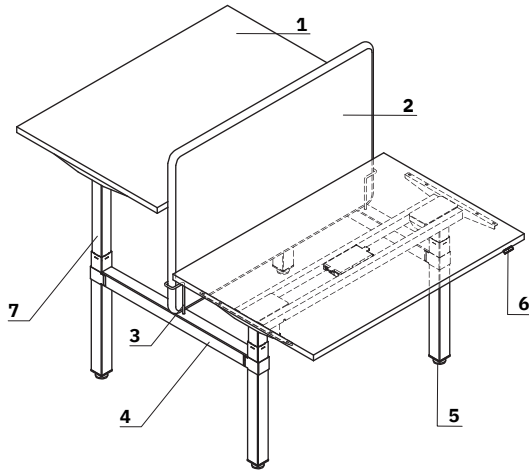

ATTENTION - distance between bench worktops 90 mm

1. **Worktop** - MFC 28 mm, ABS edge
2. **ZD Panel** - acoustic class A, zip fastener, pinable
3. **Fixing element** - powder coated metal
4. **Metal element for legs connecting**
5. **Leveling feet** - range 5 mm
6. **Control panel** - stepless height adjustment:
 - A - basic control panel; the sensitivity of the anti-collision system is set to Medium
 - B - OPTION WITH EXTRA CHARGE - up and down keypad with memory; the ability to change the sensitivity of the anti-collision system within 3 levels: Low, Medium, High
 - C - OPTION WITH EXTRA CHARGE - round control panel with memory; the ability to change the sensitivity of the anti-collision system within 3 levels: Low, Medium, High; mounted to the worktop
 - D - OPTION FOR AN ADDITIONAL COST - bluetooth module:
 - * compatible with both panel A and B
 - * the ability to change the sensitivity of the anti-collision system within 3 levels: Low, Medium, High
 - * control via MDD Desk BT application (downloadable from Google Play or App Store). The app has a time interval function that informs the user about the need of changing body position (from sitting to standing or standing to sitting)
7. **Electric height adjustable frame** - powder coated steel, load 100 kg, telescopic leg

A

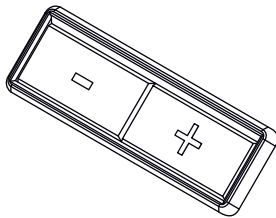

B

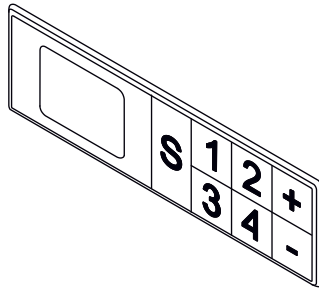

C

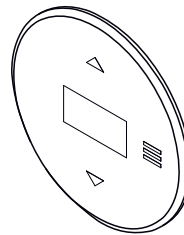

D

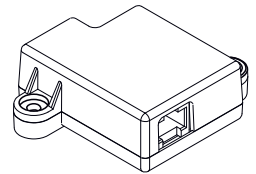

Frame technical specification

- Height adjustment** - 40 mm/sec Super Soft Start - Stop
- Drive** - 2 synchronised motors with microprocessor, work control sensor
- Noise level** - < 48dB
- Anti colision mechanism**
- Standards** - EN 527-2
- EU Directives** - 206/95EC, UI508 1999, UL 1004 R7 06, WE DC 2004/108WE Stand - by mode 0.3 W
- Power supply** - 230V, 256W

Electric frame with common cable tray - Giada

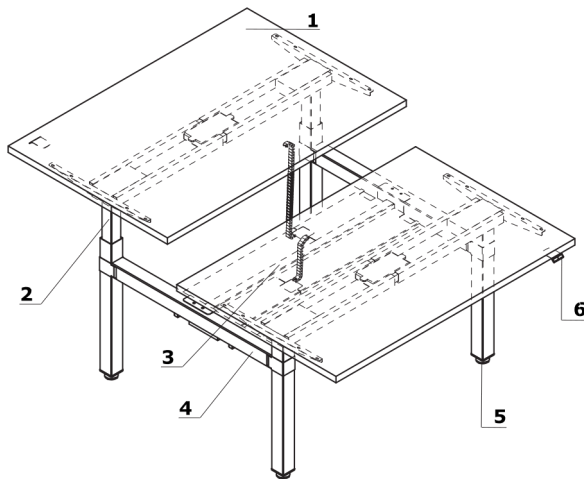

1. **Worktop** - MFC 28 mm, ABS edge
2. **Electric height adjustable frame** - powder coated steel, load 100 kg, telescopic leg
3. **Common cable tray + vertical cable organizer**
4. **Metal element for legs connecting**
5. **Leveling feet** - range 5 mm
6. **Control panel** - stepless height adjustment:
 - A - basic control panel; the sensitivity of the anti-collision system is set to Medium
 - B - OPTION WITH EXTRA CHARGE - up and down keypad with memory; the ability to change the sensitivity of the anti-collision system within 3 levels: Low, Medium, High
 - C - OPTION WITH EXTRA CHARGE – round control panel with memory; the ability to change the sensitivity of the anti-collision system within 3 levels: Low, Medium, High; mounted to the worktop
 - D - OPTION FOR AN ADDITIONAL COST - bluetooth module - compatible with control panel A and B - control via MDD Desk BT application (downloadable from Google Play or App Store). The app has a time interval function that informs the user about the need of changing body position (from sitting to standing or standing to sitting)

Mediabox location

- A - left mediabox
- B - left/right mediabox
- C - right mediabox

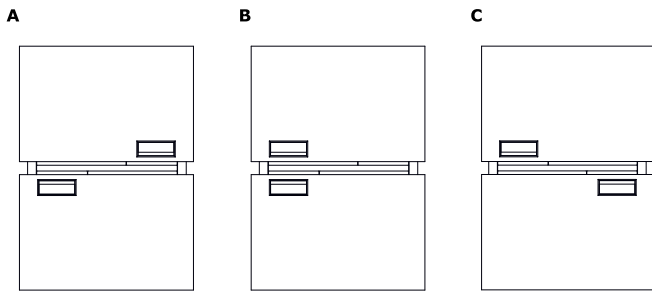

www.auraadesign.co.uk

Accessories

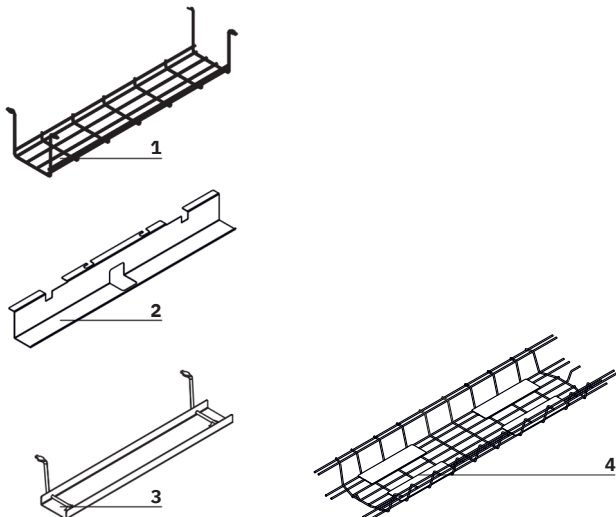

1. **Horizontal cable tray** - powder coated, colour: aluminum
2. **Single desk horizontal cable tray** - powder coated metal, colour: aluminum semi-matt
3. **Horizontal cable tray** - powder coated, colour: aluminium semi-matt
4. **Cable tray for bench desks Giada** - powder coated, colour: aluminium semi-matt

Giada handle - dimensions (mm)

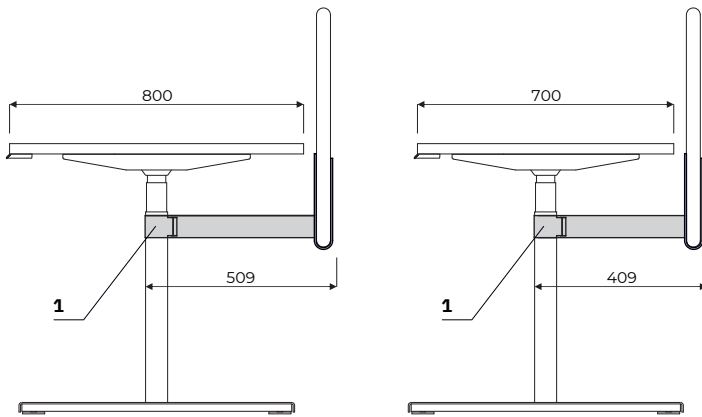

1. Giada screen bracket - an option with extra charge; mountable to the frame; powder-coated metal, 60x60mm profile

Caution - Giada screen bracket does not allow for pairing with screens equipped with accessories rail.

Power strip - for series connection

1. Set for 1 workstation - power strip (3x SCHUCKO, 2x RJ45) x1 + power cord (universal outlet PL/FR/Schucko)
2. Set for 2 workstation - power strip (3x SCHUCKO, 2x RJ45) x2 + set of power cords (universal outlet PL/FR/Schucko)
3. Set for 3 workstation - power strip (3x SCHUCKO, 2x RJ45) x3 + set of power cords (universal outlet PL/FR/Schucko)

www.auraadesign.co.uk

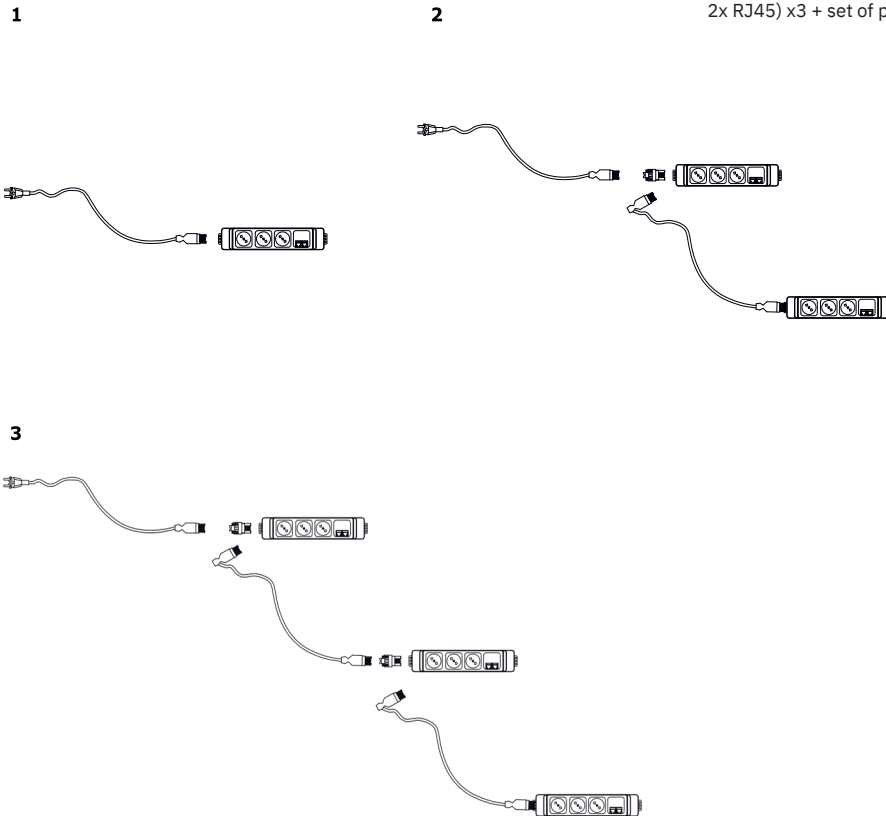

Simple desks electric height adjustment in the range of 700-1200 mm - sit-stand *



1200 / 700 / 700-1200
44.15 kg



1400 / 700 / 700-1200
48.2 kg

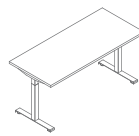

1600 / 700 / 700-1200
52.55 kg

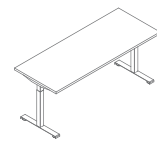

1800 / 700 / 700-1200
54.05 kg

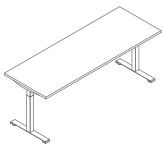

2000 / 700 / 700-1200
54.3 kg

www.auraadesign.co.uk



1200 / 800 / 700-1200
47.75 kg



1400 / 800 / 700-1200
50.65 kg

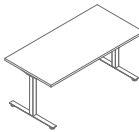

1600 / 800 / 700-1200
55.5 kg

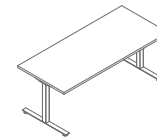

1800 / 800 / 700-1200
58.45 kg

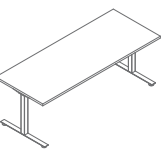

2000 / 800 / 700-1200
62.25 kg

* dimensions expressed in millimetres: width x depth x height

Single desks with electric height adjustment in the range of 650-1300 mm - sit-stand *



1200 / 700 / 650-1300
46.68 kg



1400 / 700 / 650-1300
50.73 kg



1600 / 700 / 650-1300
55.08 kg

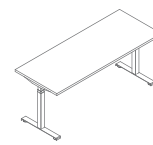

1800 / 700 / 650-1300
56.58 kg

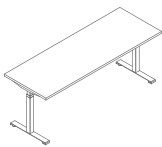

2000 / 700 / 650-1300
56.83 kg

www.auraadesign.co.uk



1200 / 800 / 650-1300
50.28 kg

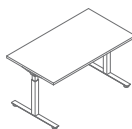

1400 / 800 / 650-1300
53.18 kg

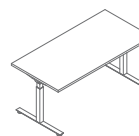

1600 / 800 / 650-1300
58.03 kg

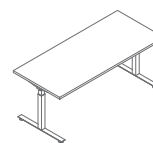

1800 / 800 / 650-1300
60.98 kg

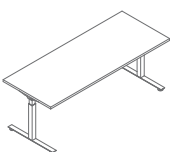

2000 / 800 / 650-1300
64.78 kg

* dimensions expressed in millimetres: width x depth x height

One leg desk electric height adjustment in the range of 650-1300 mm - sit-stand *

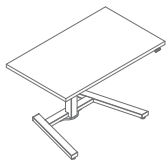

1000 / 600 / 650-1300
25 kg

Sonic - acoustic screens for bench desks *

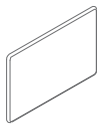

1190 / 40 / 800
6.1 kg

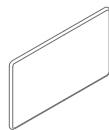

1390 / 40 / 800
8.6 kg

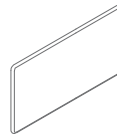

1590 / 40 / 800
7.9 kg

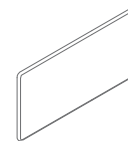

1790 / 40 / 800
8.9 kg

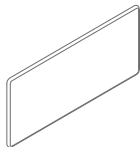

1990 / 40 / 800
9.3 kg

www.auraadesign.co.uk

Power strip



500 / 430 / 569
1.1 kg



500 / 430 / 569
1.6 kg

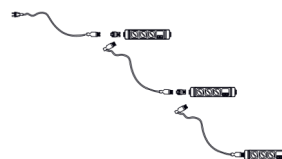

500 / 430 / 569
2.1 kg

* dimensions expressed in millimetres: width x depth x height

Worktop



Aluminum satinato



Canadian oak

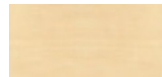

Polar birch



Cocoa

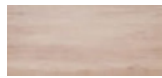

Natural oak



Honey oak

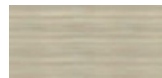

Acacia



White pastel



Dark walnut



Lowland walnut



Anthracite



Black



Grey oak

Frame - metal



Aluminum semi-matt



White semi-matt



Antracite semi-matt



Black semi-matt



Olive semi-matt **



Blue semi-matt **



Brick red semi-matt **



Yellow semi-matt **



Beige semi-matt **

Mediabox - metal



Aluminum semi-matt



White semi-matt



Antracite semi-matt



Black semi-matt

Grommets



Grey



Black



Beige



White pastel

Foot Pro



Aluminum semi-matt



White semi-matt



Antracite semi-matt



Black semi-matt



Polished aluminum ***

* body - II group

** additional charge option: one-time charge for the colour (200 €) + 10% of the product value

*** OPTION WITH EXTRA CHARGE

aura design



Hub Spaces, 582 Honeypot Lane, Stanmore, HA7 1JS, UK
www.auradesign.co.uk
020 3915 8008
info@auradesign.co.uk